

SliceScope Pro Systems

Complete electrophysiology & imaging solutions



SliceScope Pro electrophysiology systems

These systems have been developed to be modular, flexible and easy to use. Allowing users to control microscope, manipulators and mounting platforms - all from two simple, user consoles.

The SliceScope is a stable, fully-motorised microscope; designed to meet the demands of electrophysiology studies and related imaging techniques. It is the central component of Scientifica's SliceScope Pro Systems offering a cost-effective, complete solution for electrophysiology studies - to suit current and future research needs.



Slim design - ample space

The SliceScope is designed with a unique, slim profile, allowing easy placement of equipment in close proximity to the sample. This overcomes the limitations of other bulkier 'Y'-shaped microscopes, which restrict access.

The SliceScope can also be switched between *in vitro* and *in vivo* configuration for further flexibility, and cost advantage. Whilst maintaining unrivalled stability.

Quality engineering - reliable results

The SliceScope combines outstanding electrical design with industry-leading optics; providing silent, motorised movement and enabling superb image quality.

The light path design is based on established Olympus optics, ensuring a wide range of observation methods can be used to enhance experiments.

Time-saving motorisation

Full motorisation provision for the condenser and objective focus allows accurate, remote control for fine image optimisation. This neatly integrates with Scientifica's ultra-stable, micromanipulators and range of motorised stages. These products combine to allow swift navigation and effortless return to sites of interest.

By removing the need for manual adjustment the user reduces the risk of vibrations disrupting pipette placement or interfering with delicate recordings.

Versatile - a cost-effective solution

The SliceScope can be used with a wide range of illumination techniques, including; IR-DIC, Dodt and Oblique contrasting, as well as epifluorescence excitation. Therefore, improving any return-on-investment.

Scientifica's **Multiphoton Imaging System** can be easily integrated with an existing SliceScope, offering a cost-effective solution for this revolutionary technique.

Reference - Professor Dimitri Kullmann

"We have been very pleased with the Slicescoppe. It has all the best optical qualities of a top-flight microscope, pared down to the absolute essentials needed for patch-clamp electrophysiology, and then rebuilt with many highly useful features including motorised focus and condenser.

It is highly stable and has a minimal footprint, clearly the result of listening to the experimenter's needs combined with clever design."

The SliceScope frame - slimline,
motorised & solid



SliceScope frame features



Key & accessories



1 Interfacing accessories

For connection to trinocular head and eyepieces, or C-Mount cameras, from all major manufacturers.



2 Imaging shelf

Accepting Epifluorescence illumination turrets and the attachment of multiphoton scanheads.



3 Objectives

Accepts swing or sliding nosepieces, for swift exchange between high and low magnifications (accepting Olympus objectives). A motorised objective changer (MOC) is also available- (3A)



4 Condensers - fully motorised focus

Accepts both air and oil immersion condensers, including those required for DIC contrasting. Motorised for optimal Koehler illumination.



5 Motorised objective focus

Hands-free adjustment and reduction of vibration risks, this also allows for the storage of memory positions.

7 Compact, stainless steel column

For complete optical stability with a narrow profile.

9 Bright field illumination port

Standard Olympus lamphouse port for visible or IR illumination, also accepts Scientifica's own Sci-LED

11 Diffusion mirror switch

For adjusting diffusion and intensity of transmitted light.



6 Scientifica infrared LED

Can be fitted to the bright field illumination port when only IR illumination is required.

8 Substage optics

Completely removable for *in vivo* applications.

10 Mounting points

For secure anchoring to anti-vibration tables or translation stages.

12 Field iris control

For simple image adjustment.

SliceScope Pro system guide

The SliceScope has been designed to form the central component of a complete electrophysiology setup. The rest of this package includes micromanipulators, control devices and either a moving stage or moving microscope mounting solution.

A complete system requires two control devices and the user can determine their own combination from the below options.

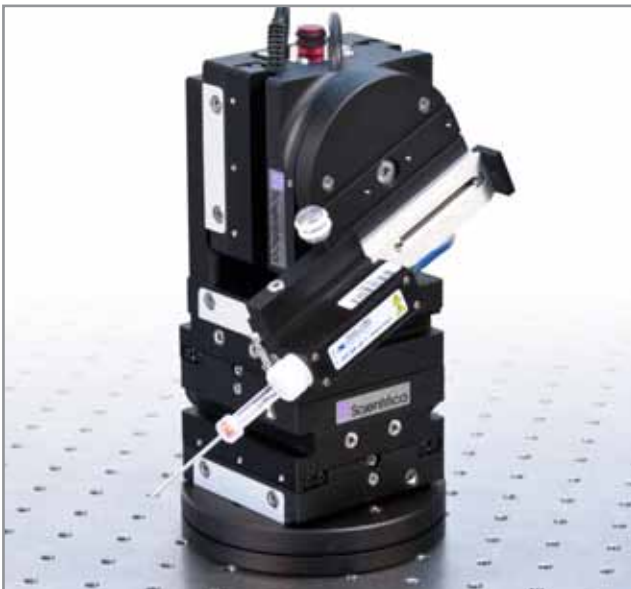

Smooth, stable micromanipulators

In addition to the SliceScope, the SliceScope Pro systems include Scientifica's world-leading PatchStar micromanipulators.

Ultra-stable with extremely low electrical noise, the PatchStar's modular design makes it extremely flexible for a wide range of positioning requirements. It features 20 mm of smooth travel over three axis, and a further fourth 'approach' axis.

An alternative option are Scientifica's ultra-compact MicroStar micromanipulators. With a width of just 33 mm, these are ideal for users studying synaptic connectivity and networks - up to eight MicroStar's can be positioned around a microscope.

Manipulators are controlled by a choice of Scientifica's control devices; Control Cube, PatchPad or Joystick as well as free, open-source **LinLab** software.

Control devices

The control devices offer a diverse choice to the user, providing flexible and intuitive control whatever the user preference.

The Control Cube is a compact, wheeled design, with fingertip control. It provides fast access to a variety of functions including activating the 'approach' axis, adjusting speed, setting and recalling memory positions and more.

The PatchPad is a flat panel design also with three wheels, each allocated to an axis of movement. It includes the same easy access buttons and switches as the Control Cube.

The Joystick offers intuitive directional control in all three axes with movement speed proportional to the amount of deflection applied.



Options for mounting and movement

Having decided upon a choice of manipulator and control devices, a user needs a solid base to complete their setup. Scientifica's motorised stages and fixed mounting systems offer superb stability combined with smooth translation throughout experiments.

A key point for consideration is whether imaging inputs restrict microscope translation in X and Y. To overcome experimental constraints Scientifica offer a SliceScope Pro package to meet all research demands.



Moving stage

For multiphoton, confocal, or other imaging techniques (where a laser input will prevent movement of the microscope) the sample and micromanipulators can be moved relative to a fixed-position microscope. The SliceScope Pro 3000 and 6000 systems provide this functionality (p10 & 11).



Moving microscope

If there are no restrictions on microscope movement, X-Y translation can be achieved via movement of the microscope with fixed position posts (or a platform) to support the sample and manipulators. The SliceScope Pro 1000 and 2000 systems (p8 & 9) incorporate this approach.

Free software with "Follow function"

Scientifica's free **LinLab** software allows the user to customise and adapt their system. They can set movement speed, direction, step sizes and store unlimited memory positions. The unique '**Follow function**' is an excellent example of how motorised elements are integrated together allowing the user to virtually link manipulators and stages to keep pipettes in the field of view, whilst searching for areas of interest.

"Saves a lot of time"

"The 'Follow function' allowed us to place one recording electrode and then make the other recording electrode follow the objective to another region of interest so that you never lost the position of the second electrode. This greatly facilitated the experiments as it saves a lot of time when you are placing multiple electrodes."

Dr Sarah Threlfell
Department of Physiology, Anatomy and Genetics
University of Oxford

Complete solutions

SliceScope Pro 1000

The SliceScope Pro 1000 is a moving microscope imaging system. Ideal for researchers who prefer the flexibility of Post and Platform mounting for their sample, manipulators and other equipment.

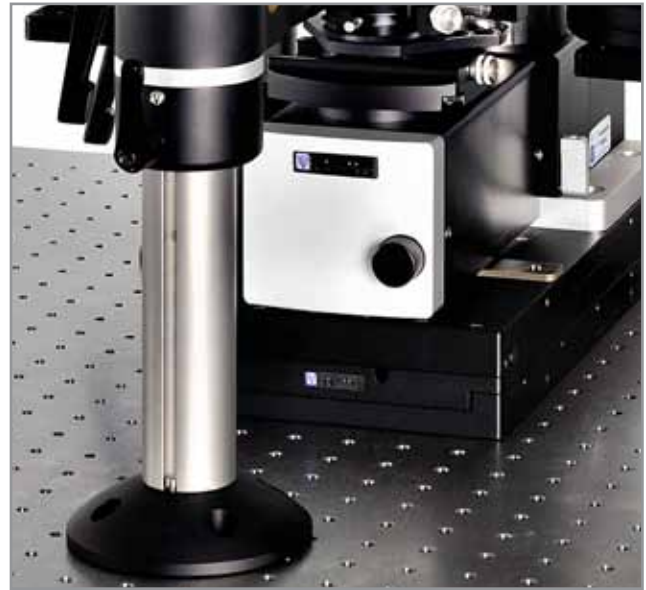
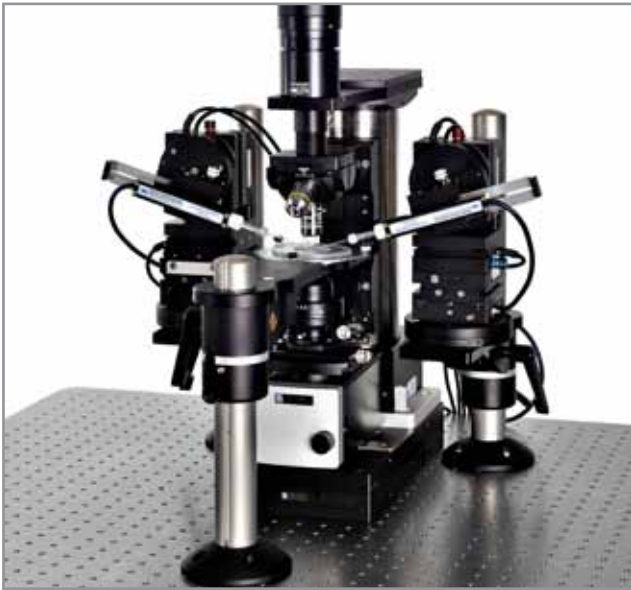

Post & Platform system

The flexible Post and Platform system is constructed of robust steel uprights for maximum stability. They can be placed anywhere on the anti-vibration table, offering complete freedom whilst maintaining open space around the microscope.

The user can choose between bolt down or magnetic attachment to the anti-vibration table. As well as taking advantage of the repeatable locking collar to return equipment to a defined starting point.

Motorised XY Stage

In this configuration the SliceScope is translated using the Motorised XY stage which provides 50 mm of smooth, accurate and intuitive translation in X and Y.

This enables the user to explore a large sample without disturbing established electrode placement. This can be controlled via any of Scientifica's control hardware or **LinLab** control software.

A standard system contains

- 1x SliceScope
- 2x Micromanipulators
- 2x Post & Platform manipulator mount
- 1x Post Sample Plate Holder
- 1x Motorised XY Stage
- 2x Control devices
- 1x Sample Plate & Slice Recording Kit

Details

- Fully-motorised microscope
- PatchStars or MicroStars
- Screw down & magnetic base available
- 50 mm travel
- PatchPad, Control Cube or Joystick
- Recording chamber & perfusion tools

SliceScope Pro 2000

The SliceScope Pro 2000 is a moving microscope system, created for researchers who prefer to use a large fixed-stage as the basis for their experimental setup.

This configuration allows the user to easily search the sample for further areas of interest, whilst retaining established patches.

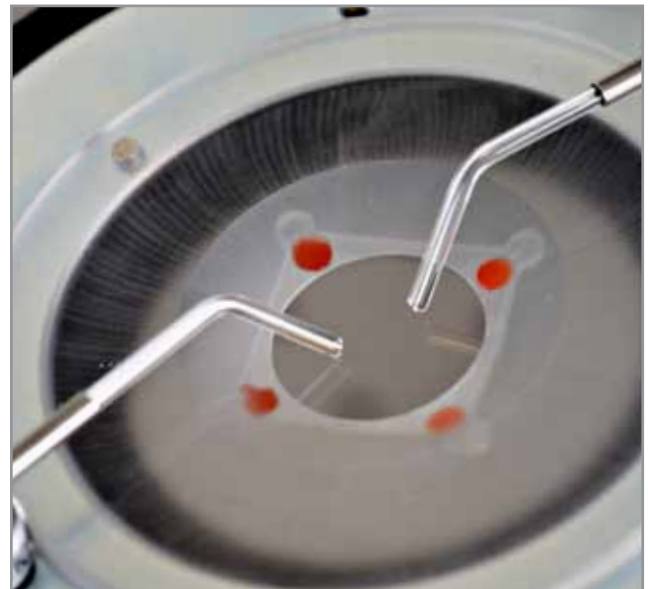

The SlicePlatform

Featuring height-adjustable legs and sliding, lockable mounting carriages, for mounting manipulators, the SlicePlatform offers increased mounting space around the sample for other experimental equipment.

It features an M6 or $\frac{1}{4}$ - 20 hole pattern to secure devices to its surface and a multi-position attachment device to easily fix it to any anti-vibration systems.

Sample Plate

The SlicePlatform features a locking sample chamber at its centre, compatible with industry standard 108 mm and 110 mm chamber adaptors.

It is possible to locate up to four PatchStars or eight MicroStars around this sample plate, keeping options open for all future research developments.

A standard system contains

1x SliceScope

2x Micromanipulators

1x SlicePlatform

1x Motorised XY Stage

2x Control devices

1x Sample Plate & Slice Recording Kit

Details

Fully-motorised microscope

PatchStars or MicroStars

50 mm travel

PatchPad, Control Cube or Joystick

Recording chamber & perfusion tools

SliceScope Pro 3000

The SliceScope Pro 3000 is a fixed microscope imaging system, designed to overcome the limitations imposed by confocal and multiphoton techniques.

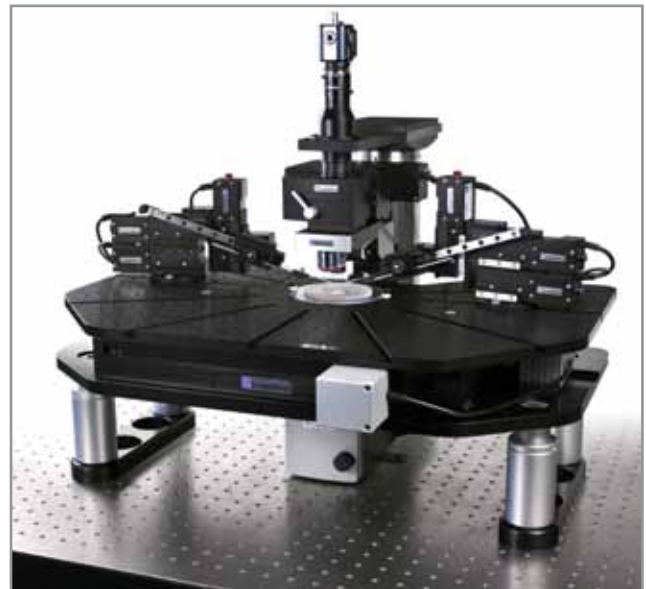
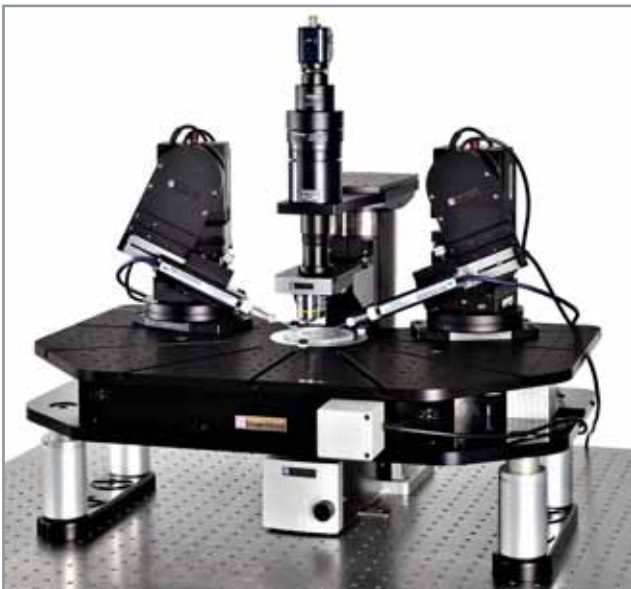

The Motorised Movable Top Plate (MMTP)

The MMTP offers a large mounting area with 25 mm of smooth motorised movement. Up to 50 memory positions can be stored via the control hardware, to enable swift return to identified interest areas.

The ultra-low noise electronics enables sensitive signal recordings to continue throughout sample adjustment.

Easy translation

This system offers the ability to effortlessly translate the entire experimental setup to allow recording from all areas of the sample.

The MMTP provides smooth, remote control movement; whilst maintaining exceptional stability required to retain delicate patches.

A standard system contains

- 1x SliceScope
- 2x Micromanipulators
- 1x Motorised Movable Top Plate
- 2x Control devices
- 1x Sample Plate & Slice Recording Kit

Details

- Fully-motorised microscope
- PatchStars or MicroStars
- 25 mm XY movement, 20 nm resolution
- PatchPad, Control Cube or Joystick
- Recording chamber & perfusion tools

SliceScope Pro 6000

The SliceScope Pro 6000 is a fixed microscope imaging system, offering maximum flexibility for both *in vitro* and *in vivo* studies.

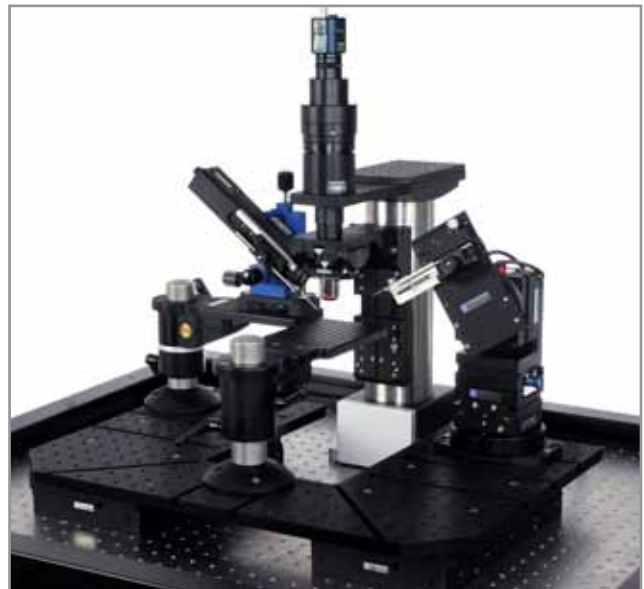
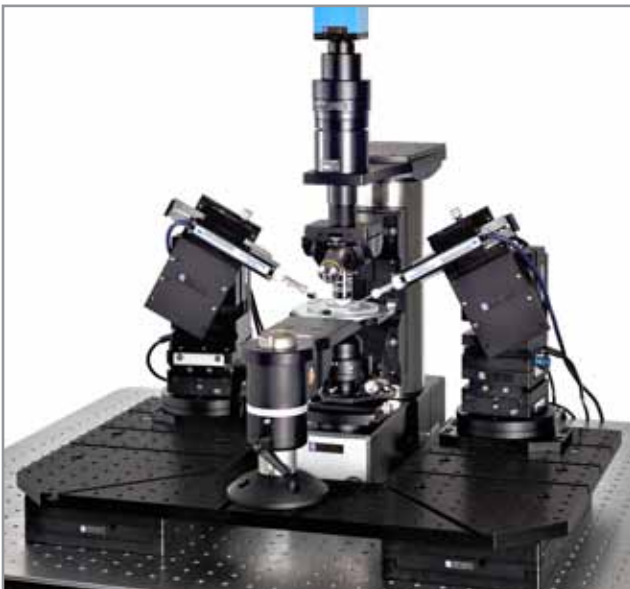

Motorised Movable Base Plate (MMBP)

The large mounting area and low-level of the MMBP offers ample space around the sample for different equipment configurations.

The MMBP features 50 mm of smooth motorised movement, translating the sample and manipulators as one. This is an ideal solution for imaging techniques which demand a stationary, laser input point.

In vivo applications

The SliceScope and MMBP are the ideal partners for *in vivo* studies. With the SliceScope's substage optics removed (see page 12), the MMBP's low height and large mounting area offers unrivalled space for manipulators, sample and life support equipment.

This setup can then be swiftly reconfigured for *in vitro* use, with a small post and platform for a chamber based sample.

A standard system contains

1x SliceScope
2x Micromanipulators
1x Motorised Movable Base Plate
1x Post & Platform Sample holder
2x Control devices
1x Sample Plate & Slice Recording Kit

Details

Fully-motorised microscope
PatchStars or MicroStars
Ideal for multiphoton & <i>in vivo</i> research
Supplied with <i>in vitro</i> or <i>in vivo</i> plate
PatchPad, Control Cube or Joystick
Recording chamber & perfusion tools

One microscope - unlimited potential

In vitro & *in vivo* exchange

For laboratories with needs that are expected to evolve over time, Scientifica have designed the SliceScope to be swiftly exchanged between *in vivo* and *in vitro* experiments.



In vitro

The *in vitro* configuration of the SliceScope includes the nosepiece arm, condenser and substage optics, with room to add extra equipment, thanks to its slimline design.

In vivo

For *in vivo* applications, the condenser and substage optics are not required and therefore can be simply removed by the user; this provides plenty of space to position the specimen and any peripheral equipment required.

For users who will not need to use the SliceScope for *in vitro* applications, (even beyond the current experimental needs), it can be purchased with just the components required for *in vivo* use.

Multiphoton imaging

A versatile & future-proof system

Scientifica have built on the solid foundations of their SliceScope microscope and offer versatile modules, these combine with the SliceScope to create a complete, Multiphoton Imaging System.

Whether looking for key components to integrate into a current 'DIY' development process or provision of a fully-operational system ready to image - Scientifica has the solution.

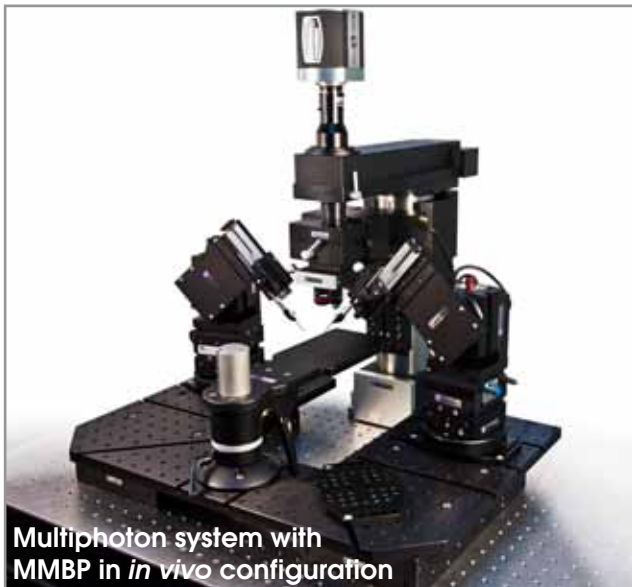

Superior image quality

The Scientifica Multiphoton System can be used in a number of configurations to meet the varying demands of different experiments.

The Scientifica Multiphoton Detection Unit (MDU) can be fitted above or below the sample to allow for maximum photon collection.

Scientifica's Scanhead has been developed to achieve optimum scanning across the field of view; providing high resolution and fast scanning for the imaging of the smallest structures.

Perfect for electrophysiologists

The compact design makes Scientifica's system perfect for electrophysiologists who also require the placement of multiple manipulators around the sample.

With the SliceScope's unique adaptability the multiphoton system can be used in either *in vitro* or *in vivo* configurations.



Technical specifications

Optical

Condenser travel

Focusing

Nosepiece options

Specifications

26 mm

Motorised nosepiece in Z-axis 26 mm

Olympus Swing Nose Piece (WI-SRE3), Scientifica Motorised Objective Changer (MOC)

General

Materials

Mounting surface

Specifications

Column: Stainless steel

Condenser & Nosepiece Arms: anodised aluminium

Metric or 1/4 20 tapped tables

Imaging

Contrast techniques

Illumination

Camera mounting

Transmitted illumination port

Specifications

DIC, Oblique, Dodt (gradient) contrast and Phase contrast

Infra-red and epifluorescence

Accepts C-mounting & direct image ports

Accepts all Olympus fitting light sources and collimating adapters



Schematics

Full system dimensions (measurements in mm)

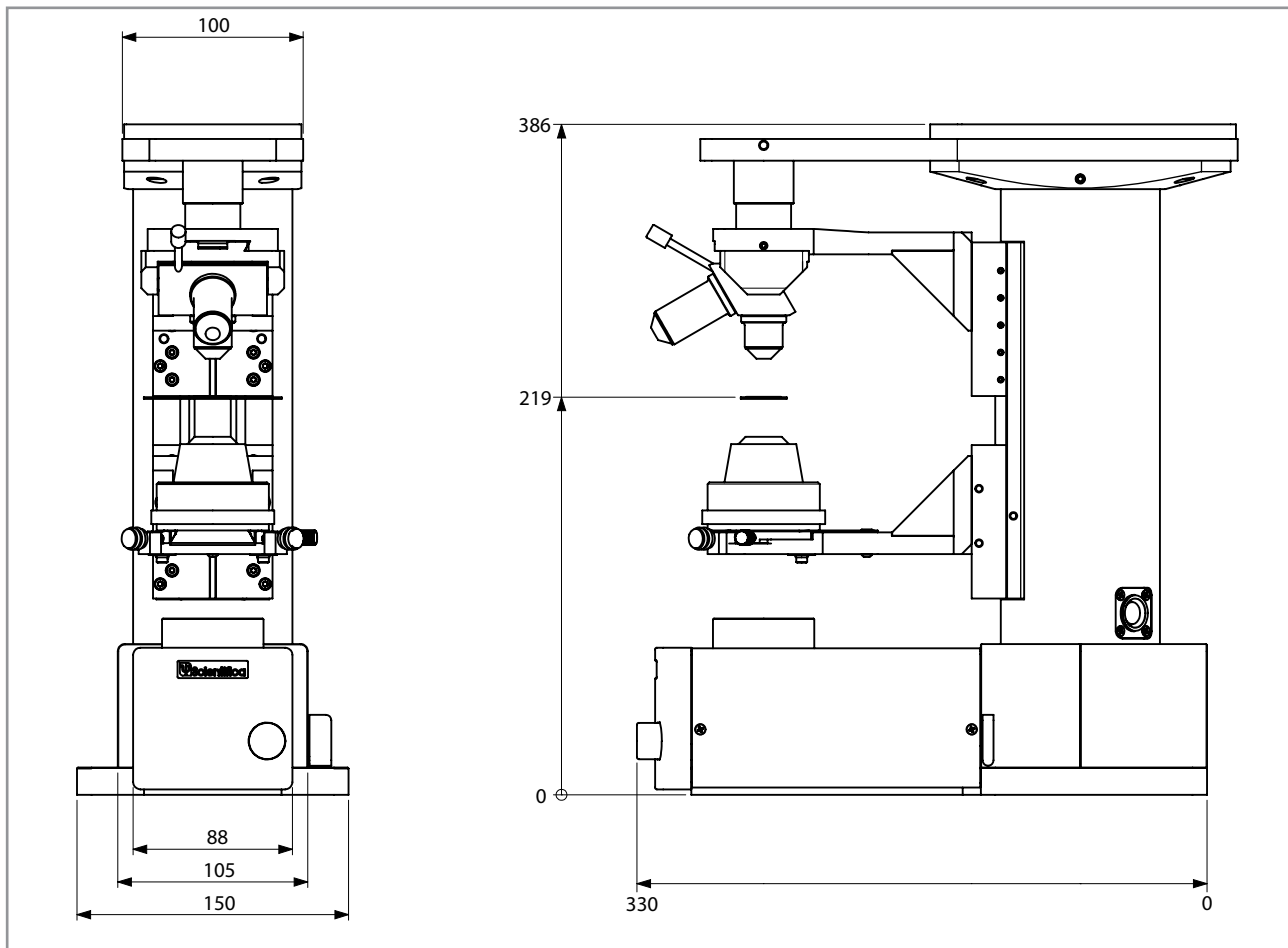

Warranty & Support

Scientifica's success is founded on supplying superior support and application of our significant manufacturing experience. We would therefore really value the opportunity to understand your applications better and to offer no obligation advice on equipment, configurations and compatibility.

All Scientifica instruments are sold with a two-year warranty giving you complete peace of mind. This covers all defects in manufacturing and materials. In this unlikely event, Scientifica will remedy either by repair or replacement.

Our team of customer support engineers is dedicated to providing you with the very best advice and support, should you experience any difficulties with our products. With all products we offer a complete installation support service.

YouTube Channel

Find out more about the Scientifica range of products and interviews on our channel, including a full demonstration of the PatchStar.

www.youtube.com/scientificauk



Scan Me!

www.scientifica.uk.com



Revision 1.3

Tel: +44(0)1825 749933
Fax: +44(0)1825 749934
Email: info@scientifica.uk.com
Web: www.scientifica.uk.com

SCIENTIFICA LTD
Kingfisher Court
Brambleside
Bellbrook Industrial Estate
Uckfield
East Sussex
TN22 1QQ
UK



THE QUEEN'S AWARDS
FOR ENTERPRISE:
INTERNATIONAL TRADE
2012