

PatchStar Micromanipulator

Stable, precise and reliable

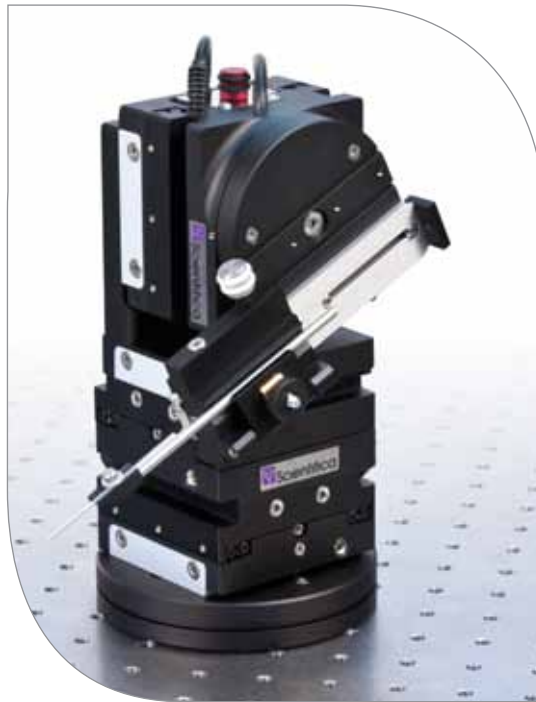
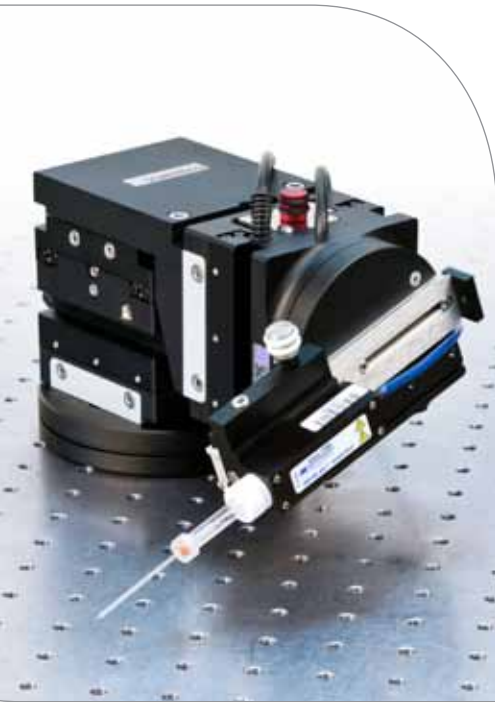

The PatchStar micromanipulator

Stable and reliable - for demanding applications

The PatchStar has been designed for the accurate (and repeatable) placement of recording and stimulating electrodes - crucial for electrophysiology experiments. It is also ideal for a broader range of applications which require delicate positioning.

The PatchStar's motorised movement is based on over ten-years, solid engineering, and has become the standard manipulator of choice in laboratories throughout the world.

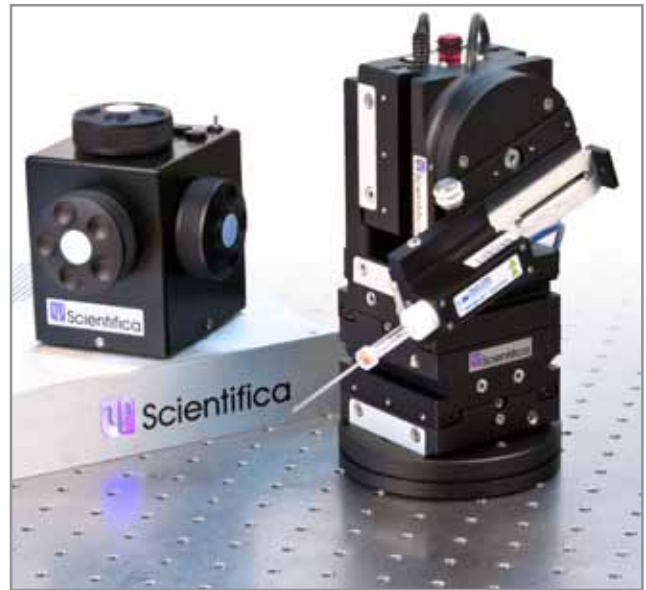
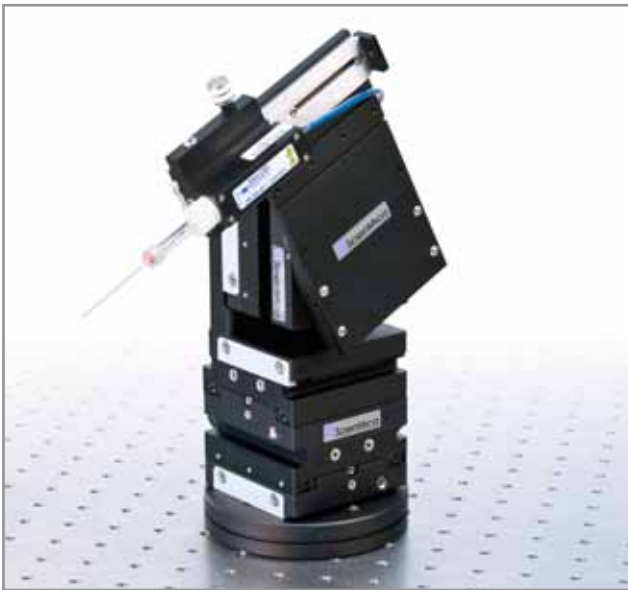

Stable and smooth movement

Developed in collaboration with leading electrophysiologists throughout the world. The PatchStar has been carefully engineered for low-drift operation (less than 1 μm in 2 hours). This is vital for users studying fine structures, or recording for long periods. This helps to prevent disturbance of established patches; which can waste valuable samples and time.

The PatchStar also boasts a small footprint - helpful when space around the microscope is at a minimum.

Low-noise electronics - accurate recordings

The low-noise motors of the PatchStar are encased within each axis, allowing the user to accurately, and without interference, record even weak signals. This is crucial for users making single-channel recordings, improving accuracy and reliability of recordings.

Modular and cost-effective

Each axis of the PatchStar is a separate unit, offering complete flexibility. By simply loosening two screws on the dovetail attachment the user can remove a module for reconfiguring.

The user can adapt the manipulator to suit their individual requirements, changing from right to left-handed operation. Or configuring it to a low-profile, with the addition of a simple bracket.

Scientifica's free **LinLab software** allows the user to pre-set movement, speed, angle of approach and utilise the unique "Follow Function". This allows the user to move multiple devices together "as one".

4th 'virtual approach' axis

A simple flick of a switch activates the PatchStar's fourth 'virtual approach' axis. This allows the user to approach the sample along the axis of the probe, for precise electrode placement.

It is fast and trouble-free as the unique 'Smart Sensor' technology removes the need to manually measure, or set, the angle. Low-resolution motors operate concurrently to eliminate "staircasing", for smooth movement even when viewed under high magnification.

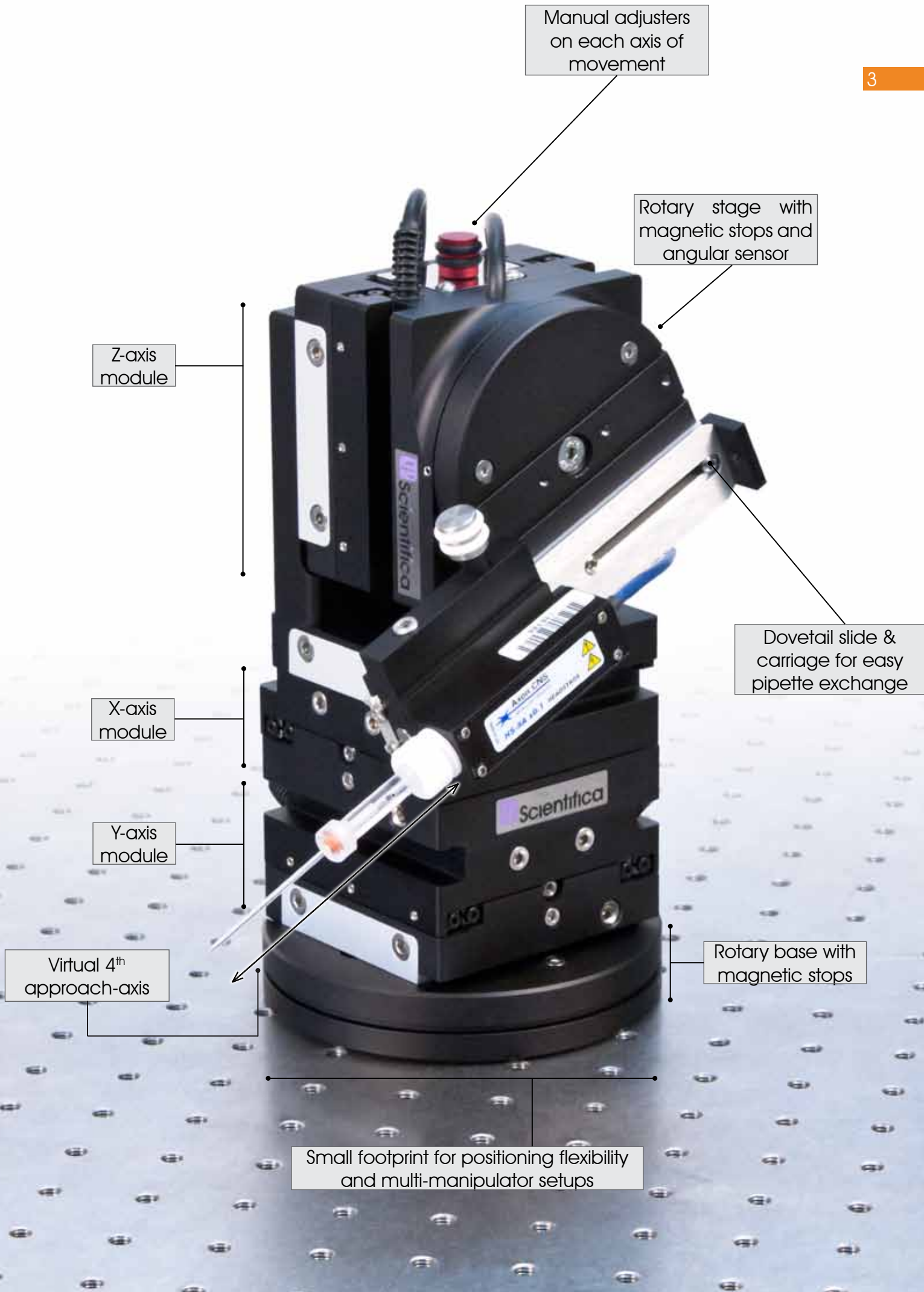

PatchStar benefits

Stability combined with high-precision

The PatchStar has been developed to be intuitive and convenient to use whilst providing crucial stability and precise, smooth movement. Solid engineering and innovative control devices have been designed to save time and enable repeatable and consistent data.



Accurate and repeatable

The PatchStar provides 20 mm of movement in each axis, with 20 nm resolution throughout its range of travel. This provides the user with absolute control for fine positioning. The user can also set the speed of movement to meet their exact requirements.

The superior, stepper motors ensure smooth, consistent movement. This allows for the precise placement of electrodes - **with less than one micron of drift in two hours.**

In addition to solid engineering and design, the PatchStar features both mechanical and magnetic locks providing additional stability.

The rotary base, and approach stage, feature user-defined, magnetic locks which can be set to allow swift removal of the probe from the sample area. This ensures accurate return to a point of interest, with micron accuracy and facilitates quick pipette exchange. As a result, productivity as well as result yield improves.

Adaptable and innovative

Scientifica's free **LinLab software** allows the user to customise and adapt their system to their exact needs. Users can set movement speed, direction and step size; store unlimited memory positions and integrate movement of multiple motorised devices.

The unique **'Follow Function'** is an excellent example of how motorised elements are integrated together. It allows the user to virtually link manipulators and stages to keep pipettes in the field of view, whilst searching for areas of interest.

The PatchStar's modular design, featuring three identical motors, also allows the manipulator to be easily reconfigured and exchanged between left and right-handed operation.

This contrasts with other systems where the researcher is required to specify orientation at point of order. Additionally, in the unlikely event of a motor failing it can be removed and exchanged to a less crucial position whilst it is being repaired.

Multiple manipulator setups

Scientifica's multiple-manipulator setups provide a fully integrated and small footprint solution to complicated electrophysiology experiments.



Double PatchStar rigs

The double PatchStar system retains all the benefits of a single PatchStar, with the added convenience of being controlled by a single control rack.

Manipulators are controlled by a choice of Scientifica's control devices; Control Cube, PatchPad or Joystick, as well as free software.

Each PatchStar can be specified with its own control device (see page 8), or alternatively, one control option can be selected to alternate between control of each manipulator. Therefore saving money and laboratory space.

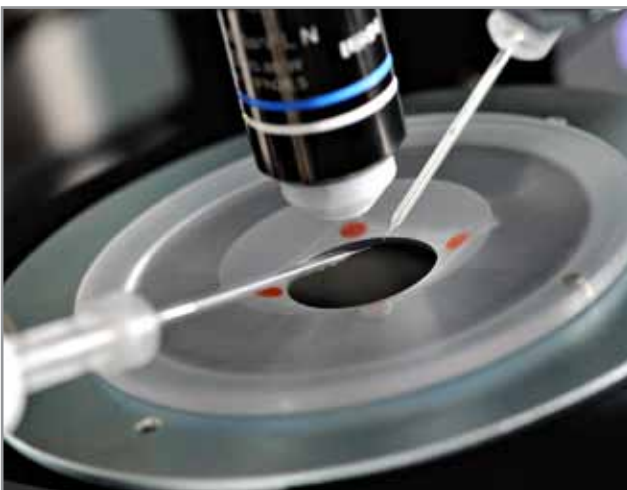

Complete electrophysiology setups

Scientifica's dedicated team of product specialists can also help specify an entire rig of integrated equipment.

Micromanipulators, translation stages, through to temperature control (and even Scientifica's SliceScope motorised microscopy system) can all be efficiently multi-plexed into the same control system and PC interface.

PatchPro & SliceScope Pro Systems

For even greater return-on-investment the PatchStar can be purchased as part of Scientifica's SliceScope Pro or PatchPro packages. A SliceScope Pro system includes the slimline, ultra-stable SliceScope motorised microscope. Whilst PatchPro systems are compatible with upright or inverted microscopes from all major manufacturers.

These systems contain everything required to begin patch clamp and imaging studies, including two manipulators, a choice of mounting options and control devices. For more information, speak to a sales representative or visit the website.

Scientifica's PatchStar customers



“The PatchStar is the new standard”

“We have bought [from Scientifica] a complete setup dedicated to dendritic patch clamp recordings. As we are recording from thin distal dendrites (micron range), stability is critical. We were naturally going to buy the usual set of nec-plus-ultra manipulators. But we decided to test the PatchStar from Scientifica.

We were genuinely impressed with its extreme stability. We ran tests under high flow rate (10 ml/min), and after 1 hour the pipette had not moved in a detectable manner. We decided to take the risk and be unfaithful to what we considered were the gold standard of manipulators.

The PatchStar is the new standard. After 6-months of use, we are still truly impressed by the stability. Once a stable series resistance is set, at the start of recording sessions, we are able to perform long duration dendritic recordings

Dr. Christophe Bernard
 Université de la Méditerranée,
 Marseille - France

Pascale P. Quilichini, Michel Le Van Quyen, Anton Ivanov, Dennis A. Turner, Aure lie Carabalona, Henri Gozlan, Monique Esclapez, and Christophe Bernard (2012). Hub GABA Neurons Mediate Gamma-Frequency Oscillations at Ictal-like Event Onset in the Immature Hippocampus. *Neuron* 74, 57–64, April 12, 2012

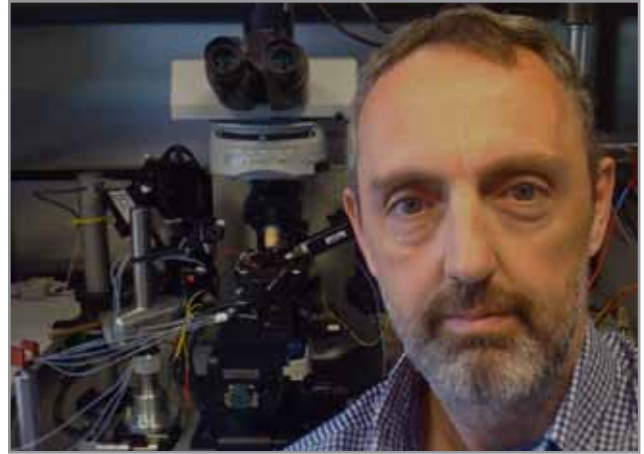

“Rock solid stability”

“We are long-time users of PatchStar micromanipulators for *in vitro* electrophysiology. We study ionotropic GABA and glutamate receptors and make conventional patch clamp recordings from neurons and glia in acute brain slices or in dissociated cultures, as well as recordings from transfected HEK cells.

We use whole-cell, cell-attached and outside-out configurations – the latter often combined with ultra-fast agonist application. In each case, successful patching demands smooth controllable motion and rock-solid stability.

Over the years we have used a variety of manual, hydraulic, motorised and piezoelectric manipulators for our work.

Since purchasing our first pair of PatchStar manipulators we have not looked back. The manipulators provide outstanding mechanical performance with intuitive and reproducible control. For high-resolution macroscopic recordings and single-channel studies the complete absence of any added electrical noise is the icing on the cake.”

Professor Mark Farrant
 Department of Neuroscience,
 Physiology and Pharmacology
 University College London

Bats, C., Soto, D., Studniarczyk, D., Farrant, M., and Cull-Candy, S.G. (2012). Channel properties reveal differential expression of TARPed and TARPless AMPARs in stargazer neurons.

Nature Neuroscience 15, 853–861

Optional accessories

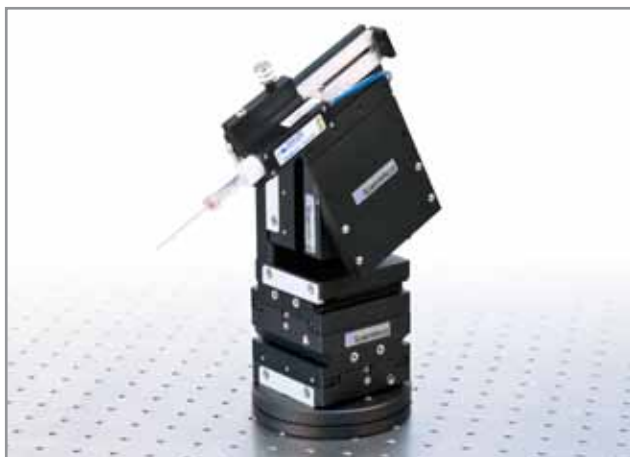

PatchStar steep bracket (PS-7550)

Allows steeper angles, or additional reach, for headstages or probes. This is recommended if mounting on Scientifica's Motorised Moveable Base Plate.

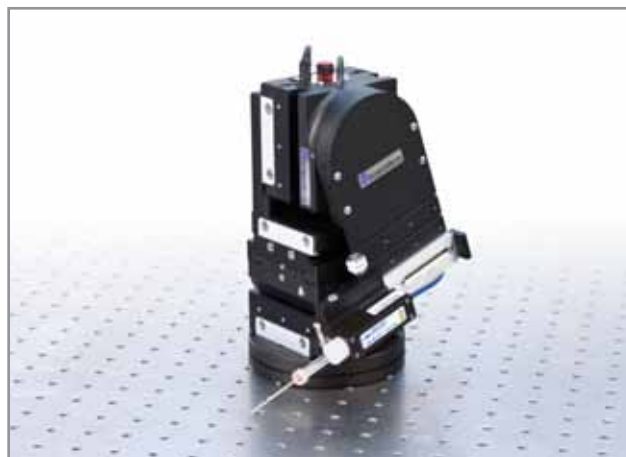

PatchStar shallow bracket (PS-7500)

Creates a low, shallow angle for positioning headstages or probes. This is suitable for applications where the PatchStar is mounted at the same height as the sample (for example, in conjunction with Scientifica's SlicePlatforms).



PatchStar flip-up bracket (PS-7700)

Flip up bracket, enabling the rotation of the pipette to a vertical position for easy pipette exchange. Convenient when space is limited.

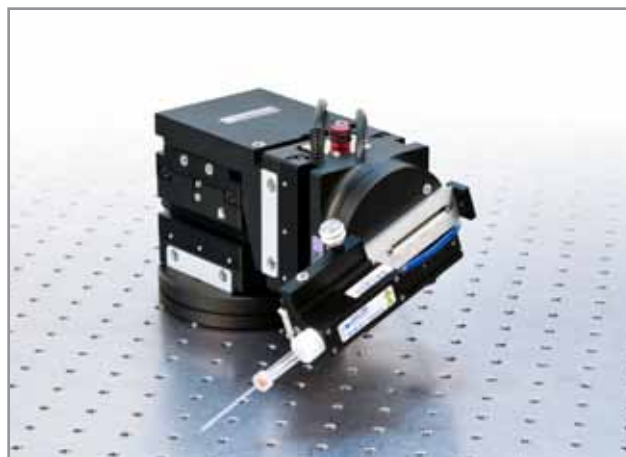

L-Bracket for low profile PatchStar (PS-7800)

Allows the position of the Z stage to be changed, lowering the height of the PatchStar. This is useful for rigs with severe height restrictions and reduces the height from 205 mm to 121 mm.

To attach

Axon headstages (CV-7A, CV-203BU, CV-8B)
 HEKA headstages
 Stimulation bars, or headstages with mounting bar
 Probes
 Bars or probes

Accessory

Standard carriage
 Dovetail strip for Heka headstage
 Universal Rod holder and carriage slide
 Fixed Sliding Probe Carriage
 Dovetail Probe Holder

Part number

-
 HEK-Dovetail
 PS-7600
 PS-7750
 PH-1000

For more information, or to discuss specialist requirements, please get in touch.

Control options

Scientifica offer a choice of control options that can be configured for use with the entire range of manipulators and translation stages.



Control Cube

Compact and comfortable to use, this popular wheeled design gives fingertip control and excellent functionality.

It also provides fast access to a variety of functions, including activating the 'approach' axis, adjusting speed, setting and recalling memory positions and more.

The three wheels, each corresponding to an axis of movement, can be converted by the user between left and right-handed use and customised to their preferences.

Joystick

The Joystick's ergonomic design offers intuitive directional control in all three axes.

With movement speed proportional to the amount of deflection applied, a speed change button enables the user to customise their device to their exact preference.

The PatchPad

With this flat panel design, each axis of movement is allocated a wheel on the panel.

The full array of features are conveniently accessed and customisable. It includes the same easy access buttons and switches as the Control Cube.

Additionally a touch screen variant is available for switching between more than two devices.

LinLab Software

Scientifica's free software offers the user the option to customise and adapt their system. It allows them to set movement speed, direction, step sizes; and store unlimited memory positions.

The unique '**Follow Function**' allows the user to virtually link manipulators and stages to keep pipettes in the field of view, whilst searching for areas of interest.

LinLab

LinLab is a Windows™ based program which provides further control over the PatchStar. It is free of charge to all users, along with all future upgrades.

Follow function

The unique **'Follow Function'** is an excellent example of how motorised devices can be integrated together allowing the user to virtually link manipulators and stages to keep pipettes in the field of view, whilst searching for areas of interest.

This overcomes the common problem of searching a large sample for an area of interest then having to bring pipettes into the field of view.

Once a cell of interest has been located, the recording, or stimulating electrode, can be simply "released" from follow control and the cell approached as normal.

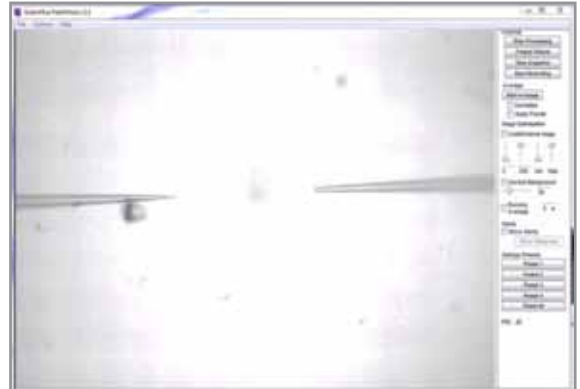

Watch the video demonstration here:
www.scientifica.uk.com/follow-function

Benefits

Adjust the two speed settings

Customise the control device

View, store, label, recall and cycle between memory positions

Control step sizes

Virtual joystick function

Programme preset step motions

Open-source, with commands to integrate with existing software.

Control up to 12 devices using a tab selection menu.

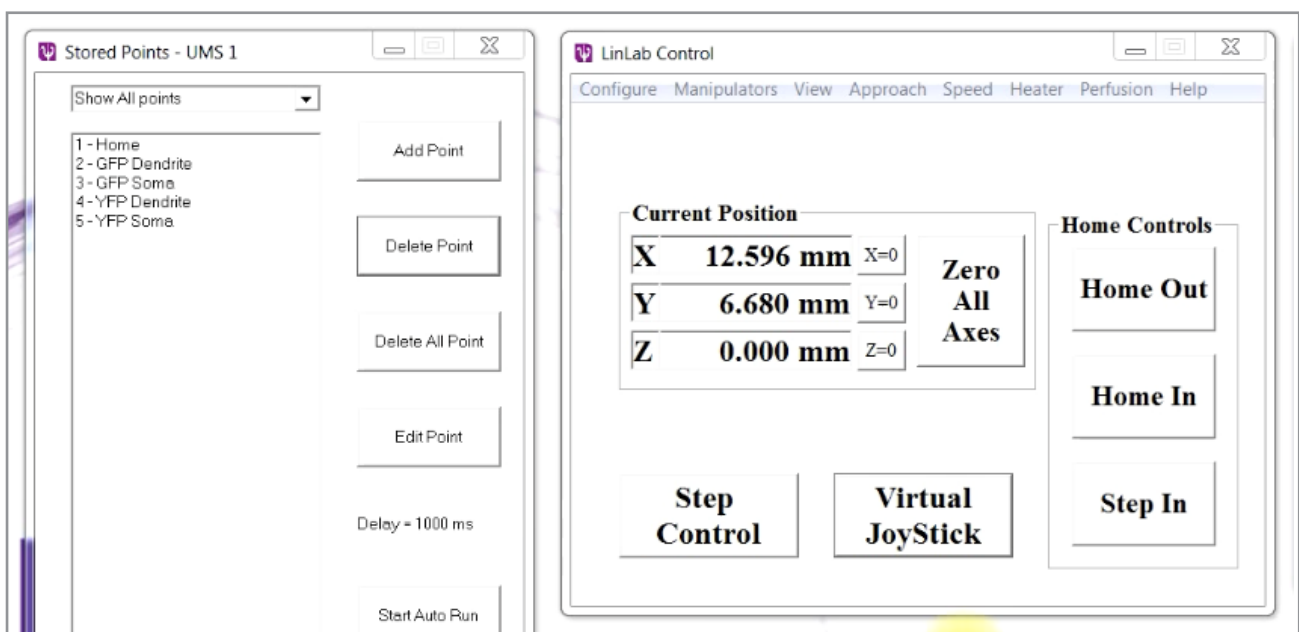

Schematics

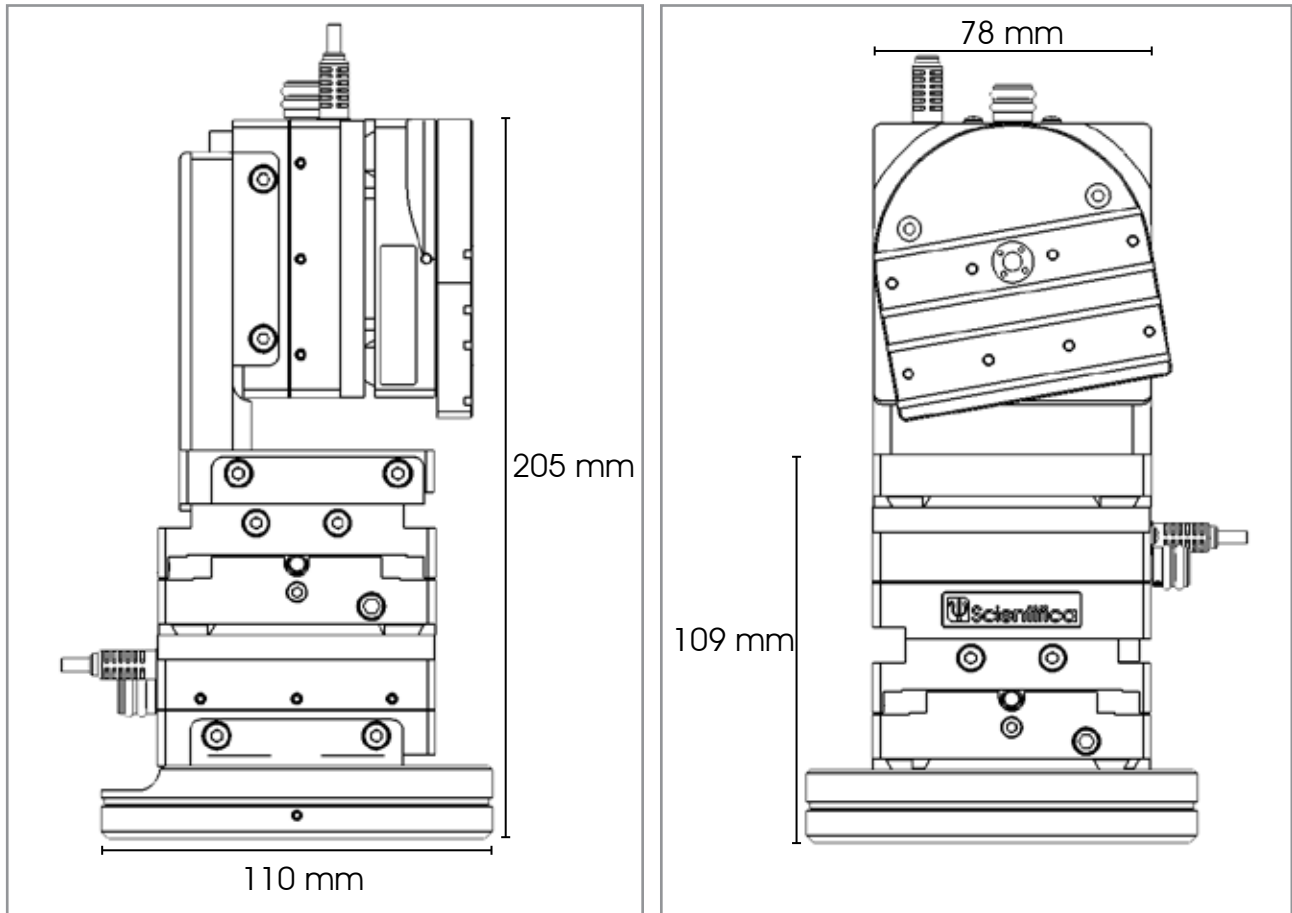

Specifications

Number of axis	3 orthogonal and virtual 4 th axis
Travel distance	20 mm
Step size	0.1 μm
Bearings	Crossed roller
Speed	(minimum) 1 μm per second (maximum) 4 mm per second
Electronic resolution	20 nm
Load capacity	200 gm
Memory positions	Up to 50 on control device (unlimited via LinLab)
Software	LinLab for Windows

Ordering information & technical specs

Product option	Code
PatchStar Micromanipulator	PS-7000
Double PatchStar Micromanipulator System with 1 controller	PS-8300
Double PatchStar Micromanipulator System with 2 controllers	PS-8200

All PatchStar Micromanipulators include: a rotary base, rotary vertical stage, dovetail slide and sliding carriage, 1U mounted rack controller (and all cabling), and LinLab software for Windows.

These order numbers should be appended with the following codes to designate choice of control option:

C = Control Cube
 J = JoyStick
 P = PatchPad
 PT = PatchPad Touch

Please speak to a member of the Scientifica team for further assistance in selecting the most appropriate equipment.

Warranty

Scientifica's success is founded on supplying superior support and application of our significant manufacturing experience. We would therefore really value the opportunity to understand your applications better and to offer no obligation advice on equipment, configurations and compatibility.

All Scientifica instruments are sold with a two-year warranty giving you complete peace of mind. This covers all defects in manufacturing and materials. In this unlikely event, Scientifica will remedy either by repair or replacement.

Our team of customer support engineers is dedicated to providing you with the very best advice and support, should you experience any difficulties with our products. With all products we offer a complete installation support service.

YouTube Channel



Find out more about the Scientifica range of products and interviews on our channel, including a full demonstration of the PatchStar.

www.youtube.com/scientificauk



Scan Me!



Revision 1.1

Tel: +44(0)1825 749933
Fax: +44(0)1825 749934
Email: info@scientifica.uk.com
Web: www.scientifica.uk.com

SCIENTIFICA LTD
Kingfisher Court
Brambleside
Bellbrook Industrial Estate
Uckfield
East Sussex
TN22 1QQ
UK



THE QUEEN'S AWARDS
FOR ENTERPRISE:
INTERNATIONAL TRADE
2012